

# ESF 103.1

Entsafter  
Juice Extractor  
Licuadora  
Centrifugadora  
Juicepressen  
Mehulinko  
Sokowirówka  
Odšť'avnovač  
Gyümölcscentrifuga  
Αποχυμωτή

Gebrauchsanweisung  
Operating instructions  
Instrucciones para el uso  
Instruções de utilização  
Bruksanvisning  
Käyttöohje  
Instrukcja obsługi  
Návod k použití  
Használati útmutató  
Οδηγίες χρήσης



**AEG**

**AUS ERFAHRUNG GUT**

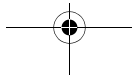
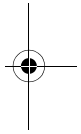

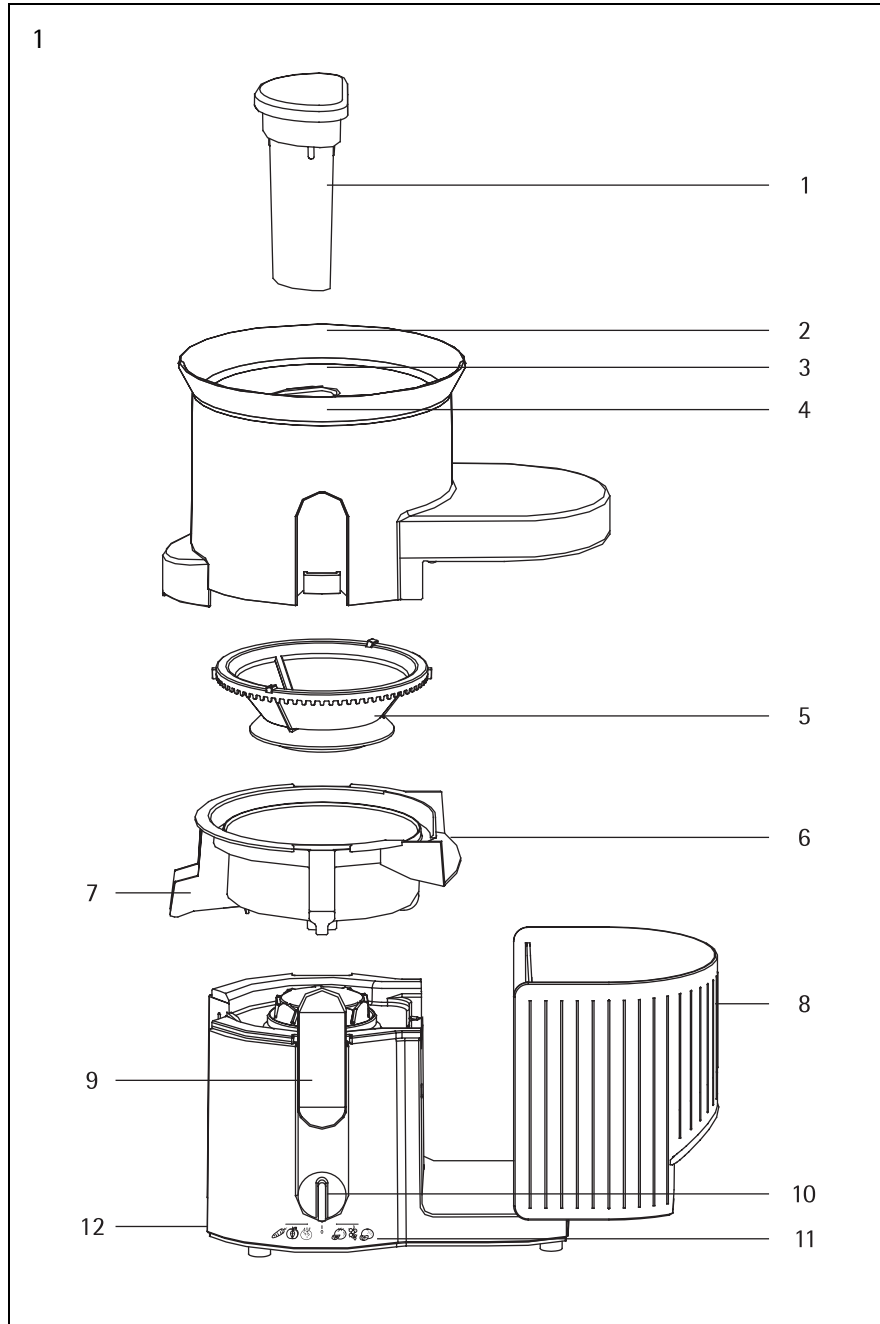

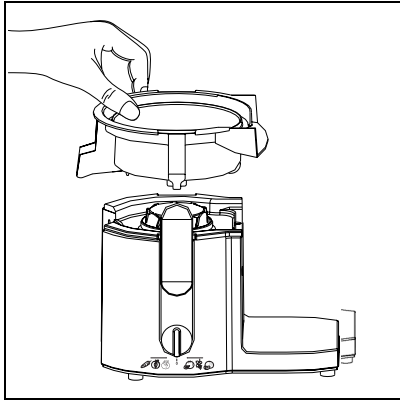

2

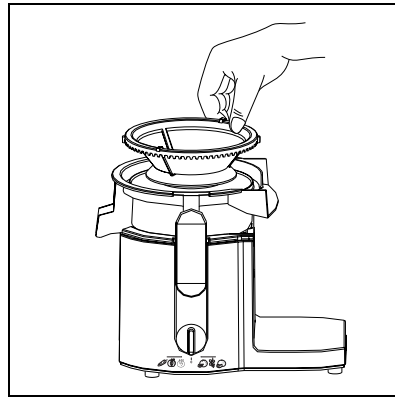

3

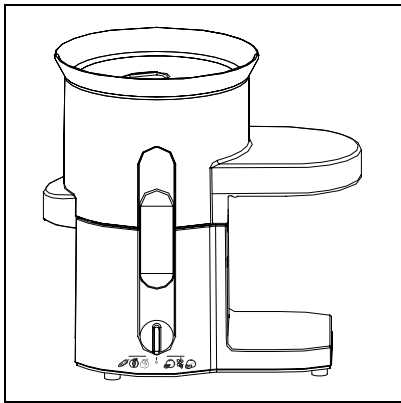

4

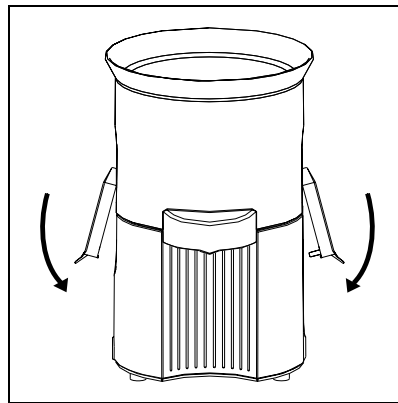

5

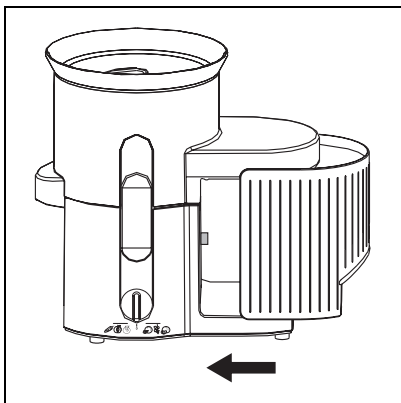

6

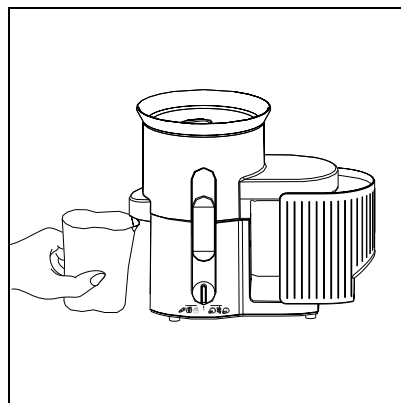

7

3

(GB)

**(GB) Dear Customer,**

Please read this instruction manual carefully. Please pay particular attention to the safety instructions. Retain it for future reference. Give the instruction manual to any future owner of the machine.

**Features (Figure 1)**

- 1 Plunger
- 2 Upper part
- 3 Filling bowl
- 4 Filling shaft
- 5 Strainer basket with grating disk
- 6 Juice bowl
- 7 Juice outlet
- 8 Residue container
- 9 Locking clips
- 10 Knob
- 11 Motor part
- 12 Flex compartment (at back of appliance)

**! Safety instructions**

Before first use, it is imperative to read through the Instructions for Use carefully!

- The operating voltage and mains voltage must agree! (See rating plate on base of juice extractor.)
- Only operate the appliance under supervision! Even if you leave the room only very briefly, switch off and unplug the appliance.
- Keep children well away!
- Never place your hand in the filling shaft when the appliance is running. When replenishing, always use the plunger. Never insert any long objects, such as kitchen knives, food slices, etc., in the filling shaft.
- Before maintenance or cleaning, make sure that the appliance is switched off and unplugged.

- Please wait until the motor has stopped, before removing the upper part of the housing.
- Never use the supply lead to pull the plug out of the socket!
- Never immerse the appliance in water!
- **Do not use the appliance if:**
  - the supply cord is damaged;
  - the housing or the strainer basket show visible damages.
- Only use the appliance if all parts are properly assembled and joined together.
- Do not remove the upper part while the appliance is in use.
- Only switch the appliance on when the plunger (Fig. 1/1) is in place.
- Take care when handling the strainer basket (Fig. 1/5). The grating disk is sharp!
- Do not open the appliance until the motor has stopped completely.
- **Repairs to electrical appliances should only be performed by a trained electrician. Improper repairs may place the user at serious risk.**
- In the event of a fault, therefore please approach your specialist retailer or the AEG Service Centre direct.
- **The appliance is only intended for processing foods at home. Should the appliance be wrongly used or for a purpose other than for which it is intended, no liability can be accepted for any possible damage.**

**CE** This appliance complies with the following EC Directives:









- 73/23/EEC of 19.02.1973 – Low-Voltage Directive.
- 89/336/EEC of 03.05.1989 (including Amendment Directive 92/31/EEC) – EMC (Electromagnetic Compatibility) Directive.

**Technical data**

Connected load: 400 W  
Voltage: 230-240V  
Continuous operation

## Assembling the juice extractor

Before first use, the appliance parts should be cleaned (section on "Dismantling and cleaning").

-  Place the appliance on a flat, dry work surface.
- Unwanted flex can be inserted into the flex compartment (Fig. 1/12).
-  Arrange the motor part in an upright position so that the knob at the front faces you.
-  Place the juice bowl with the juice outlet on the LH side of the motor part (Fig. 2).
-  Place the strainer basket in the juice bowl (Fig. 3).
-  Place the upper part with the juice outlet on the LH side (Fig. 4).
-  Engage and press down the locking clips (Fig. 5).
-  Push the residue container in properly, so that it engages (Fig. 6).
-  Place the container supplied or another suitable vessel underneath the juice outlet (Fig. 7).
-  Position the plunger.

### Safety system

The appliance can only be switched on, if all parts of the appliance are properly assembled and joined together.

- The juice bowl must be properly inserted (Fig. 2).
- The locking clips must be properly locked (Fig. 5).
- The residue container must be properly inserted, so that it engages (Fig. 6).

### Operate the appliance as follows:

For soft fruit  
and vegetables =  
Knob to the **right**

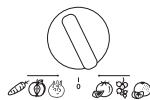

For firm fruit  
and vegetables =  
Knob to the **left**

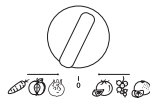



To switch off the juice extractor, turn the knob to "0".

## Juice extraction

Fill the appliance with the prepared, chopped fruit or vegetables and lightly press down with the plunger. Smaller pieces can be shaken down on to the surface of the filling bowl. With the plunger, move the fruit or vegetables towards the filling shaft. When filling fruit containing pips (e.g. grapes, tomatoes), hold the plunger when replenishing so that it always evenly covers the filling opening. When re-applying the plunger, make sure that the motor is not too strongly retarded. Make sure that the full residue container is promptly emptied. Please check that the strainer basket is free from obstruction. When the juice has been extracted from the last piece, the motor must run until juice ceases to drip.

## Dismantling and cleaning

Important note! The appliance should only be dismantled when the motor has been switched off and the appliance unplugged.

-  Take out the plunger, remove the residue container.
-  Unclip both locking clips und lift off the upper part.
-  The strainer basket and juice bowl are removed from the motor base together. Wipe the motor part only with a damp cloth! Clean all other parts in hot water or in normal washing-up water! The sooner this happens after appliance use, the more easily will cleaning proceed! Use a brush to clean the strainer basket and groove in the upper part. Please treat the appliance gently. Never scratch or scour it. Any possible discolorations (e. g. due to carrots or beetroot) can be rubbed off with vegetable oil.

**Do not clean in the dishwasher** the motor part, upper housing and plunger. Never immerse the appliance in water!

GB

## Hints on juice preparation

Observe the freshness rule:

Buy fresh, extract fresh and drink fresh, to get the most vitamins from your fruit and vegetables.

Clean the fruit or vegetables for juice extraction as single pieces. Only just before juice extraction should you chop the fruit or vegetables into pieces small enough to pass conveniently through the filling shaft.

Fresh juice are by nature not clear like packaged juices. Pulp and suspended matter are carriers of vegetable proteins, minerals, and vitamins as important constituents of fresh juices.

Stir the juice before drinking!

If the juice is to be stored in the fridge, please cover it or pour it into a clean bottle with a top to prevent contamination with flavours from other foodstuffs.

Metal containers may affect the flavour of the juice.

## Fruit and vegetables for juicing

### Root vegetables and tuberous vegetables

#### Carrots, celery, kohlrabi, radishes

Clean and peel, if necessary.

Celeriac is less suitable for juicing than celery.

#### Beetroot

Peel thinly. The skin tastes too strong and if not removed spoils the flavour of the juice.

### Leafy vegetables, cabbages

#### Curly kale, spinach, lettuce, garden herbs

Do not feed these vegetables too quickly into the juice extractor. Feed everything with soft leaves, e.g. spinach, into the juice extractor rolled into a ball.

### Cabbage

All of a red or white cabbage can be juiced. Either cut the heads into suitably sized pieces or remove the leaves from the stalk and roll them into a ball.

### Vegetable fruits

#### e.g. Cucumbers, melons, papaya, pomegranates

Do not peel or remove skins (except for melons), cut into suitably sized pieces, do not remove the centre with the seeds but extract the juice from the whole fruit.

#### e.g. Peppers

Do not juice the inner parts with the seeds and the stalk.

### Rhubarb

Rhubarb is not suitable for juicing!

### Pomes

#### Apples, pears

Always juice with the skin on. The core also does not have to be removed. Cut them up, so that they fit comfortably in the filling bowl.

### Quinces

Do not use in the juice extractor!

The very hard flesh can cause unusual load on the motor and may even cause damage to the appliance.

### Stone fruit

#### Plums, cherries, peaches

Remove stones from the fruit. When extracting the juice, only press the plunger down lightly. This increases the juice yield.

### Soft fruit

#### Redcurrants, blackcurrants and elderberries

With berries, remove only the thick stalks. Berries give a somewhat thicker juice, because they start to become gelatinous during the juicing process. (Redcurrants and blackcurrants are not suitable for juicing because they become very gelatinous very quickly.)

You can prevent the berries from squirting out if you feed them in so quickly that the filling shaft is always filled with berries. Only press them down very lightly. If the residues, e.g. from raspberries or blackberries, appear too wet to you, you can put these through the juice extractor a second time.

#### **Grapes**

Put the grapes still on their thin stalks into the filling bowl with the motor not running. Switch on, press down lightly with the plunger and when filling with further fruit, hold the plunger so that it always covers the filling aperture.

#### **Citrus fruits**

##### **Oranges, mandarins, lemons, grapefruits**

Peel citrus fruit well and remove as much of the white pith as possible, because it makes the juice bitter.

#### **Pineapple**

Remove it from its outer skin before juicing.

strainer basket and remove any debris. Clean the strainer.

- the ejection of residues is impaired.
  - Check the ejection hole and the ejection of residues.
  - If necessary, consult the Service Centre.

### **For the sake of the environment**

Do not throw away packing material.

- The cardboard box can be taken to paper recycling facilities.
- Plastic bag made of polyethylene (PE) can be taken to recycling facilities of PE collection depots.
- The filler parts are made of Polystyrene (PS). They do not contain any CFCs. Your local Department for the Environment will be able to give you advice as to where collecting depots and recycling facilities are available.

### **What to do if...**

- the appliance does not work
  - Are all parts of the appliance correctly assembled?
  - Check locking clips and safety switch.
- the speed decreases noticeably.
  - Switch off the appliance, remove the plug from the mains socket. When the motor has stopped, clean the strainer basket and the ejection hole.
- there is a noticeable unbalance in the appliance.
  - The foodstuffs from which the juice is being extracted are not equally distributed. It is possible that hard pieces have got caught on the strainer basket.

Switch off the appliance, remove the plug from the mains socket. When the motor has stopped, check the



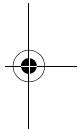
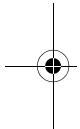
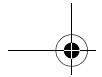

AEG Hausgeräte GmbH  
Postfach 1036  
D-90327 Nürnberg

<http://www.aeg.hausgeraete.de>

© Copyright by AEG

822 949 274 – 1203

